

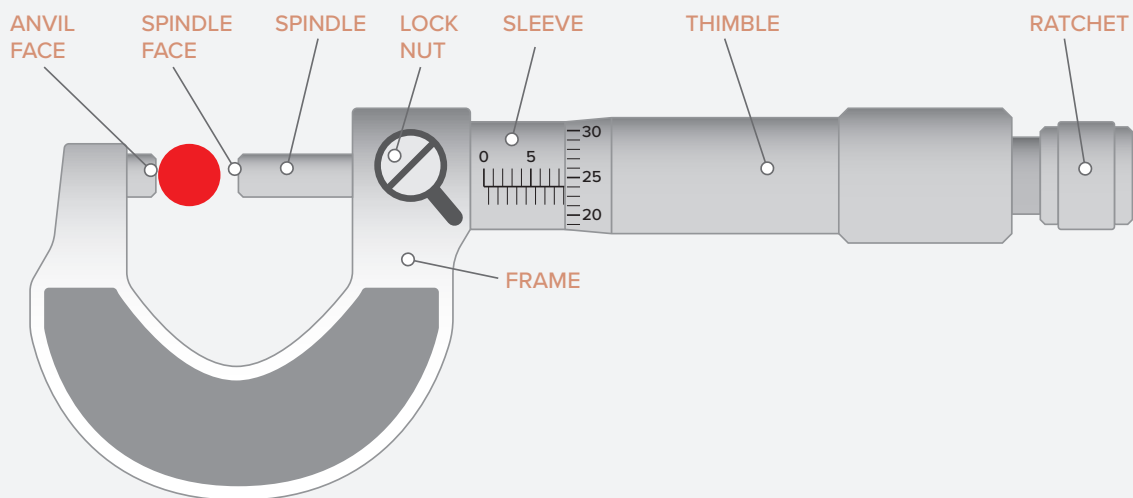

HOW TO USE A MICROMETER

A micrometer is an essential precision measurement instrument, used by engineers to measure small distances. It uses the principle of a screw to amplify small distances (that are too small to measure directly) into large rotations of the screw that are big enough to be quickly and easily read from a scale.



TO TAKE A READING

- 1 Place the object to be measured between the anvil face and the spindle face.
- 2 Turn the ratchet clockwise until the object is secured and makes a 'clicking' noise. This means the ratchet can't be tightened any more and the measurement can be taken.
- 3 Read the scale on the top of the sleeve (a). The example clearly shows 8.00mm divisions.
- 4 Read the scale on the bottom half of the sleeve (b). A further 0.5mm measurement can be seen in the example. Therefore, the measurement is 8.50mm.
- 5 Check the reading on the thimble (c). In the example this is 0.24mm
- 6 Add the two figures from the scale and the one from the thimble together for the total measurement. The total in the example is 8.74mm

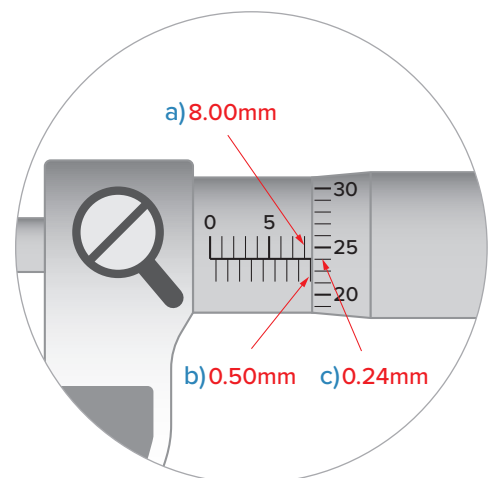

$$8.00\text{mm} + 0.50\text{mm} + 0.24\text{mm} = 8.74\text{mm}$$